

WK-CAN-200H

Walk-in Module

Model Name	WK-CAN-200H
Hardware Version	v1.0
Software Version	v1.0
Manual Version	2021-07-14

딥 스위치 설정



No.1	No.2	No.3	No.4	No.5	Car Model
OFF(▲)	OFF(▲)	OFF(▲)	OFF(▲)	ON(▼)	BMW CIC
OFF(▲)	OFF(▲)	OFF(▲)	OFF(▲)	OFF(▲)	BMW NBT
OFF(▲)	OFF(▲)	OFF(▲)	ON(▼)	OFF(▲)	BMW EVO

※차종 옵션에 따라서 시트 각 모터에서 작업 해야될수도 있습니다.

SEAT SWITCH CONNECTOR

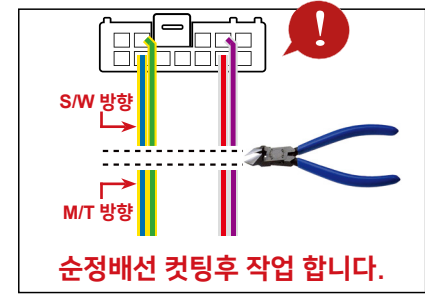

- = B+ (Red / Yellow)
- = Ground (Brown)
- = REAR S/W (Purple / White)
- = FRONT S/W (Red / White)
- = UP (Green / Yellow)
- = DOWN (Blue / Yellow)

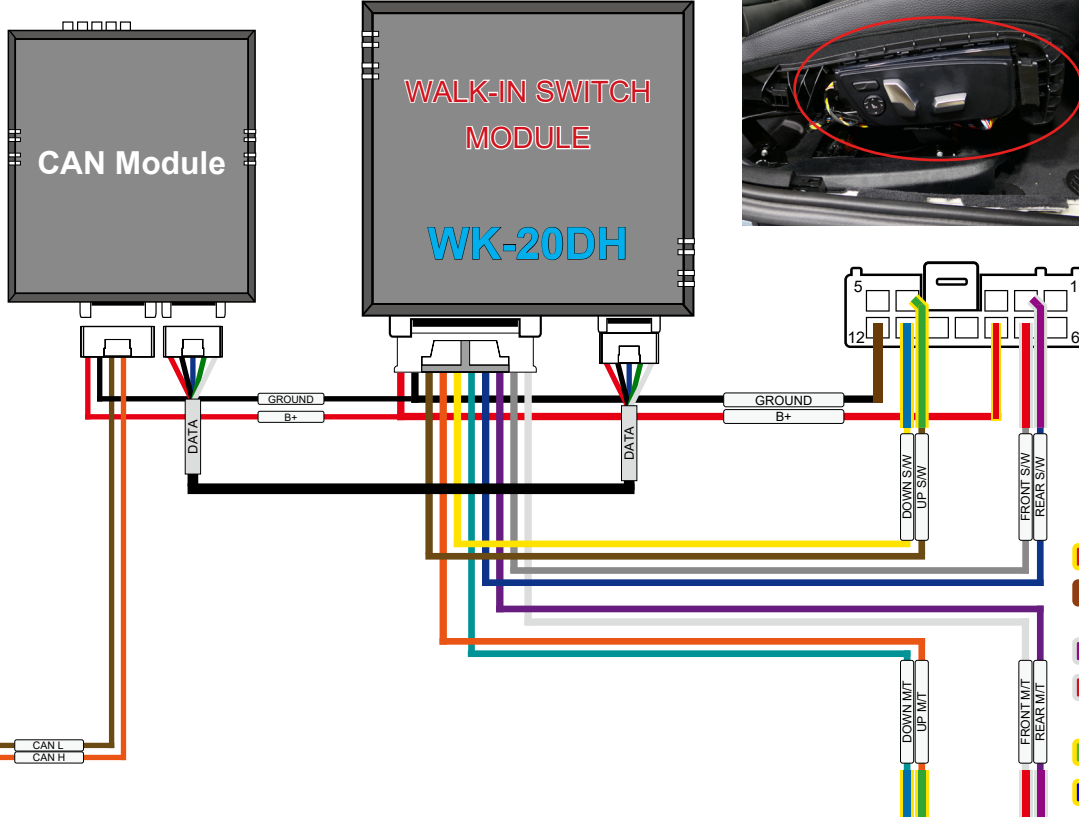

i-Drive Controller Connector



(Green) Pas Can Low = ■
 (Green / Orange) Pas Can High = ■

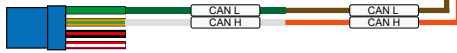

동작 방법

Button	Operation	Function
1 BACK / OPTION	버튼을 3초 이상 길게 누름	워크인 모드 활성화 (비프음 1회 발생) 3초 이상 Dial Button, Back, Option 버튼 입력이 없으면 워크인모드 해제
	버튼을 짧게 누름	모드 전환 (워크인모드 진입 이후 사용) (UP, DOWN ⇔ FRONT, BACK)
2 DIAL BUTTON	위 또는 아래로 이동	시트가 UP, DOWN, FRONT, BACK 방향으로 이동 ※워크인모드 진입 이후 사용

배선연결 명칭



Type #1 iDrive Controller

Type #2 iDrive Controller